

Godox 神牛

# AD360II-N

WITSTRO<sup>+</sup> 威客

TTL 机顶外拍两用闪光灯  
TTL Powerful & Portable Flash

For Nikon



深圳市神牛摄影器材有限公司  
GODOX Photo Equipment Co., Ltd.

地址/Add: 深圳市宝安区福永镇福洲大道西新和村华发工业园A4栋  
Building A4, Xinhe Huafa Industrial Zone, Fuzhou RD West, Fuyong

Town, Baoan District, Shenzhen 518103, China

电话/Tel: +86-755-29609320(8062) 传真/Fax: +86-755-25723423

邮箱/E-mail: godox@godox.com

http://www.godox.com

705-AD36N0-00

Made In China

FC CE RoHS 回收 禁止焚烧

中英文双语 / Chinese English Bilingual

说明手册 / INSTRUCTION MANUAL

# Foreword

---

## Before using this product

Please read this user manual carefully in order to ensure your safety and the proper operation of this product. Keep for future reference.

## Thank you for purchasing a GODOX product.

WITSTRO TTL Powerful & Portable Flash AD360II-N adopts Godox 2.4G wireless X system. When using on the camera, AD360II-N is suitable for Nikon DSLR cameras; when using Godox 2.4G wireless X system off camera, AD360II-N is compatible with Canon E-TTL II autoflash, Nikon i-TTL autoflash, etc. With master & slave functions, AD360II-N can also use in combination with Godox TTL camera flashes, TTL outdoor flashes, TTL studio flashes, etc. With this AD360II-N flash, your shooting will become simpler. You can easily achieve a correct flash exposure even in complex light-changing environments.

WITSTRO AD360II-N flash system is an AD360II-N flash with a bare tube, external power pack, wireless manual power control, and a range of dedicated light shaping accessories. AD360II-N is 5 to 7 times powerful as typical hotshoe flashes with the size and weight alike. It offers studio quality light for outdoor and live shooting. The AD360II-N offers:

- **Compatible wireless TTL system:** Fully support Canon E-TTL II, Nikon i-TTL and other TTL systems in Godox 2.4G wireless X system. Workable as Master or Slave unit in a wireless flash group.
- **Dot-matrix LCD panel:** with clear and convenient operation.
- **Built-in 2.4G wireless transmission:** with all-in-one functions and 100 meters further transmission with X1N TTL wireless flash trigger.
- **Studio quality light:** up to 360Ws, GN 80 (m ISO 100, with AD-S2 standard reflector) . One AD360II-N can overpower the sun.
- **External battery pack:** PB960 (lithium, 10.8V/5800mAh), 0.05-4.5s recycling and 450 full power flashes.
- **Lightweight and portable** even with power and accessories
- **Wireless control:** With built-in Godox 2.4G wireless X system to achieve TTL control. Godox FT-16 flash trigger can also be used to wirelessly adjust flash power level and trigger the flash. AD360II-N has 3.5mm sync cord jack and PC sync socket to achieve various sync triggering mode.
- **Wide-range accessories:** softbox, beauty dish, snoots, color gels, etc. All lighting accessories fit for barebulb flashes from most brands.

Power adjusts from full power to 1/128 in 1/3 stop increments

Stable color temperature at 5600±200K over the entire power range

1/8000s high-speed sync flash, Focus-assist beam on/off & high-speed sync triggering

The powerful and portable AD360II-N meets the demands of freelance commercial photographers, photojournalists, wedding and beach portraiture shooters, event and backpack photographers, photograph enthusiasts, etc.

# Warning

---

- ▲ Always keep this product dry. Do not use in rain or in damp conditions.
- ▲ Do not disassemble. Should repairs become necessary, this product must be sent to an authorized maintenance center.
- ▲ Keep out of reach of children.
- ▲ Stop using this product if it breaks open due to extrusion, falling or strong hit. Otherwise, electric shock may occur if you touch the electronic parts inside it.
- ▲ Do not fire the flash directly into the eyes (especially those of babies) within short distances. Otherwise visual impairment may occur.
- ▲ Do not use the flash unit in the presence of flammable gases, chemicals and other similar materials. In certain circumstance, these materials may be sensitive to the strong light emitting from this flash unit and fire or electromagnetic interference may result.
- ▲ Do not leave or store the flash unit if the ambient temperature reads over 50°C. Otherwise the electronic parts may be damaged.
- ▲ Turn off the flash unit immediately in the event of malfunction.

## Conventions used in this Manual

- This manual is based on the assumption that both the camera and camera flash's power switches are powered on.
- Reference page numbers are indicated by "p.\*\*".
- The following alert symbols are used in this manual:
  - ▲ The Caution symbol indicates a warning to prevent shooting problem.
  - 📌 The Note symbol gives supplemental information.

# Contents

27	Foreword
28	Warning
30	Name of Parts
	Body
	LCD Panel
	Included Accessories
	Separately Sold Accessories
	Installing Reflector (Other Accessories)
	Attaching Flash Tube
	Connecting to a Power Pack
	Connecting the Flash to a Camera
	Replacing the Off-Camera Adapter
34	Power Management
35	Flash Mode— i-TTL Autoflash
	FEC (Flash Exposure Compensation)
	High-Speed Sync
	Second-Curtain Sync
37	Flash Mode—M: Manual Flash
38	Flash Mode—RPT: Stroboscopic Flash
39	Wireless Flash Shooting: Optic Transmission
	Wireless Settings
	Setting Master Unit's Flash Mode
	Setting the Communication Channel
	Wireless ID Settings
	i-TTL: Fully Automatic Wireless Flash Shooting
	M: Wireless Flash Shooting with Manual Flash
	RPT: Wireless Flash Shooting with Manual Flash
43	Wireless Flash Shooting: Ratio (2.4G) Transmission
45	Other Applications
	Wireless Control Function
	Modeling Flash
	Auto Focus Assist Beam
	Assist Beam Setting
	Bounce Flash
	Sync Triggering
	PC Sync Socket Triggering
47	C.Fn: Setting Custom Functions
48	Protection Function
49	Technical Data
50	Troubleshooting
50	Compatible Camera Models
50	Maintenance

## Name of Parts

### Body:



# Name of Parts

## LCD Panel

### (1) i-TTL Autoflash

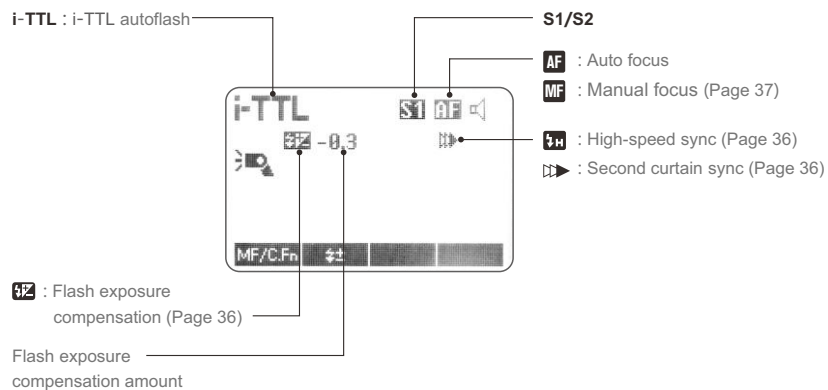

- The display will only show the settings currently applied.
- The functions displayed above function buttons 1 to 4, such as **SYNC** and **±**, change according to settings' status.
- When a button or dial is operated, the LCD panel illuminated.

### (2) M Manual Flash

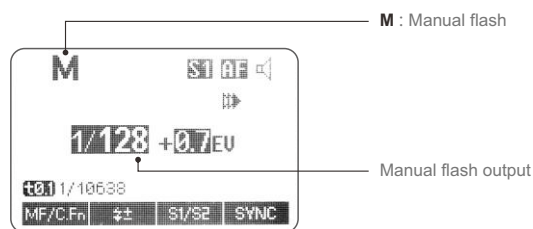

### (3) RPT Flash

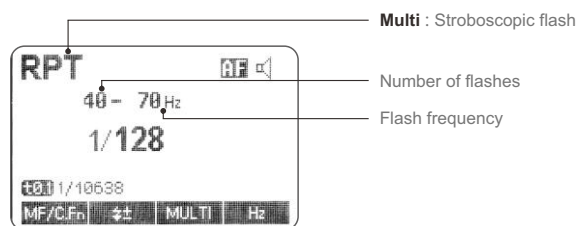

# Name of Parts

## (4) Radio Transmission Shooting/Optic Transmission Shooting

### • Master Unit

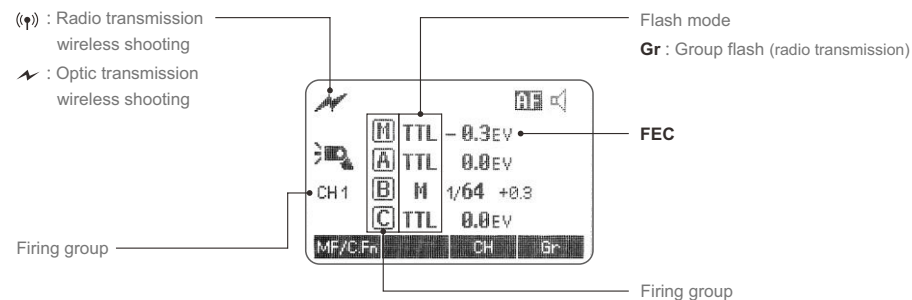

### • Slave Unit



## Included Accessories

- Flash tube\*1
- Protecting bag\*1
- Mini stand\*1
- Off-camera adapter\*1
- Reflector\*1
- Power cable\*1
- Reflector diffuser\*2
- Instruction manual\*1

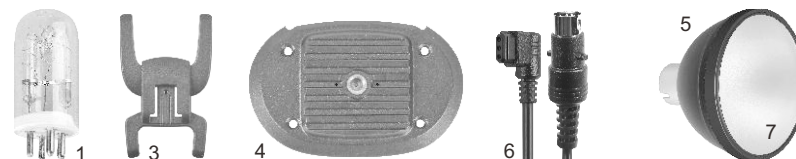

## Separately Sold Accessories

The product can be used in combination with the following accessories sold separately, so as to achieve best photography effects:

X1N Wireless Flash Trigger, FT-16 Remote Control, Softbox, Beauty Dish, Fold up umbrella, Snoots, Light stand, etc.



## Name of Parts

### Installing Reflector (Other Accessories)

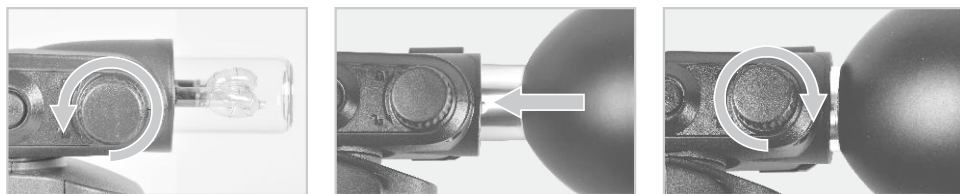

1. Rotate Accessory Locking Ring outer-clockwise until it is loosen.
2. Insert the reflector into the Accessory Mount.
3. Rotate Accessory Locking Ring clockwise to lock it up. Do not over-tighten.

### Attaching Flash Tube

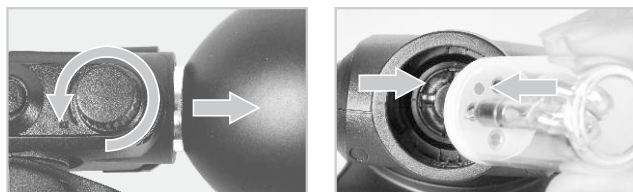

1. Remove the reflector or other accessories from the flash head.
2. Match the red dot on the base of the flash tube with the red dot in the Tube Socket. Push the flash tube in until it is securely seated into the socket.

### Connecting to a Power Pack



1. Before connecting, make sure that the power pack is turned off.
2. Plug one end of Power Cable into Power Socket of the flash unit, and insert the other end into the output socket of the power pack.
3. Turn on the power pack. Normally the flash unit will be fully charged and ready to work.

**!** The flash unit is not powered by itself, but draws power from Godox power pack PB960 (sold separately). For the instructions of the power pack, see the related user manual.

## Name of Parts

### Connecting the Flash to a Camera



1. Loosen the locking ring on the mounting foot.
2. Slip the mounting foot of the flash into the camera hotshoe.
3. Secure the flash unit by rotating the locking ring the direction of the row.

### Replacing the Off-Camera Adapter

The off-camera adapter is useful when using the product as an off-camera flash. There is a 1/4" mounting hole at the bottom of the off-camera adapter. After replacing the adapter, the flash can be used mounting on GODOX AD-S13 portable light boom, AD-S16 floor light stand, and almost any other light stand. To install the off-camera adapter,



1. Use a screwdriver (not included) to remove the four screws at the bottom of this product. Then take out the bottom part carefully as illustrated.
2. Install the off-camera adapter at the bottom of this product.
3. Tighten all the screws.

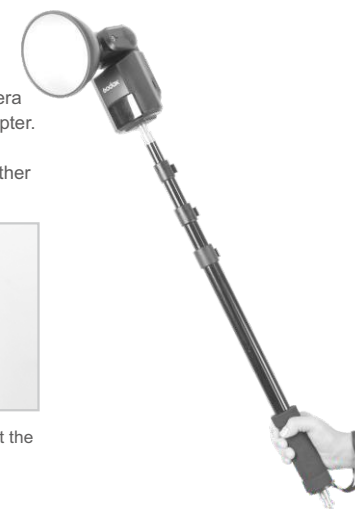

## Power Management

ON/OFF Power Switch controls the on/off of the flash unit. Turn off the power pack if the flash unit will not be used for an extended period (approx. 1 hour).

**C.Fn** Disabling Auto Power Off function is recommended when the flash is used off camera. (C.Fn-APO, Page 47)

## Flash Mode — i-TTL Autoflash

This flash has three flash modes: i-TTL, Manual (M), and Multi (Stroboscopic). In i-TTL mode, the camera and the flash will work together to calculate the correct exposure for the subject and the background. In this mode, multiple TTL functions are available: FEC, HSS, second curtain sync, modeling flash, etc.

\* Press <MODE> Mode Selection Button and three flash modes will display on the LCD panel one by one with each pressing.

### i-TTL Mode

Press <MODE> Mode Selection Button to enter i-TTL mode. The LCD panel will display <i-TTL>.

- Press the camera release button halfway to focus. The aperture will be displayed in the viewfinder.
- When the shutter button is fully pressed, the flash will fire a pre-flash that the camera will use to calculate exposure and flash output the instant before the photo is taken.

### FEC: Flash Exposure Compensation

With FEC function, this flash can adjust from -3 to +3 in 1/3rd stops. It is useful in situations where minor adjusting of the TTL system is needed based on the environment.

Setting FEC:

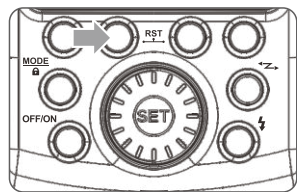

- 1 Press Function Button 2 <+/->. The icon <+/-> and flash exposure compensation amount will be highlighted on the LCD panel.

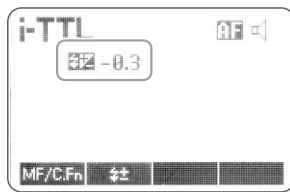

- 2 Set the flash exposure compensation amount.
  - Turn the Select Dial to set the amount.
  - "0.3" means 1/3 step, "0.7" means 2/3 step.
  - To cancel the flash exposure compensation, set the amount to "+0".

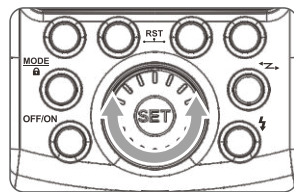

- 3 Press <SET> button again to confirm the setting.

## Flash Mode — i-TTL Autoflash

### High-Speed Sync

High Speed Sync (FP flash) enables the flash to synchronize with all camera shutter speeds. This is convenient when you want to use aperture priority for fill-flash portraits.



Select the high-speed sync icon <⚡>.

- Set the flash sync speed to 1/320s (Auto FP) or 1/250s (Auto FP) in the Nikon camera menu. Press the shutter button halfway. The icon <⚡> displayed on the flash screen means the high speed sync function is enabled on the flash.
- Turning the camera command dial can set the shutter speed to 1/250s or faster.
- To check if the FP flash function works properly, look through the shutter speed in the viewfinder. If it shows a speed of 1/250s or faster, the FP flash function is on work.

- If you set a shutter speed as 1/320s (Auto FP) or 1/250s (Auto FP) in the Nikon camera setting, <⚡> will be displayed in the flash screen regardless of practical shutter speed.
- With high-speed sync, the faster the shutter speed, the shorter the effective flash range.
- To return to normal flash, set the flash sync speed to other options other than Auto FP. Then the icon <⚡> will disappear when pressing the shutter halfway.
- Multi flash mode cannot be set in high-speed sync mode.
- Over-temperature protection may be activated after 30 consecutive high-speed sync flashes.

### Second-Curtain Sync

With a slow shutter speed, you can create a light train following the subject. The flash fires right before the shutter closes.

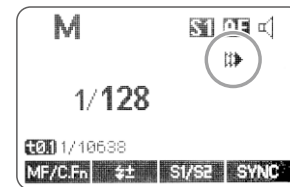

- Set the camera to Rear mode and press the shutter button halfway, then the flash display panel will show the second curtain sync icon <⇨>.
- When the camera is not set to Rear mode, pressing the shutter button halfway will not light up the icon <⇨> on the flash display panel.

## Flash Mode — M: Manual Flash

The flash output is adjustable from 1/1 full power to 1/128th power in 1/3rd stop increments. To obtain a correct flash exposure, use a hand-held flash meter to determine the required flash output.

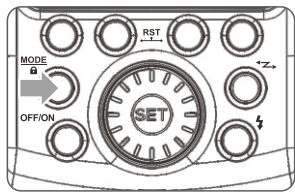

**1** Press <MODE> button so that <M> is displayed.

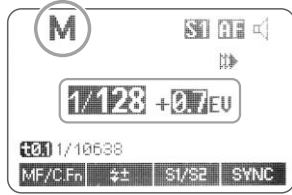

**2** Turn the Select Dial to choose a desired flash output amount.

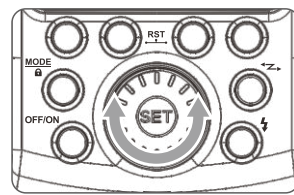

**3** Press <SET> button again to confirm the setting.

### Flash Output Range

The following table makes it easier to see how the stop changes in terms of f/stop when you increase or decrease the flash output. For example, when you decrease the flash output to 1/2, 1/2-0.3, or 1/2-0.7, and then increase the flash output to more than 1/2, 1/2+0.3, 1/2+0.7, and 1/1 will be displayed.

Figures displayed when reducing flash output level→

1/1	1/1-0.3	1/1-0.7	1/2	1/2-0.3	1/2-0.7	1/4	.....
	1/2+0.7	1/2+0.3		1/4+0.7	1/4+0.3		.....

←Figures displayed when increasing flash output level

### Optic S1 Secondary Unit Setting

In M manual flash mode, press <S1/S2> button so that this flash can function as an optic S1 secondary flash with optic sensor. With this function, the flash will fire synchronously when the main flash fires, the same effect as that by the use of radio triggers. This helps create multiple lighting effects.

### Optic S2 Secondary Unit Setting

Press <S1/S2> button so that this flash can also function as an optic S2 secondary flash with optic sensor in M manual flash mode. This is useful when cameras have pre-flash function. With this function, the flash will ignore a single "pre-flash" from the main flash and will only fire in response to the second, actual flash from the main unit.

- S1 and S2 optic triggering is only available in M manual flash mode.

### Display Flash Duration

Flash duration refers to the length of time that from flash's firing to reach the half peak at maximum. The half peak at maximum is usually expressed as t=0.5. In order to provide the photographer with more concrete data, this product adopts t=0.1. The difference between t=0.5 and t=0.1 is shown in the following picture.

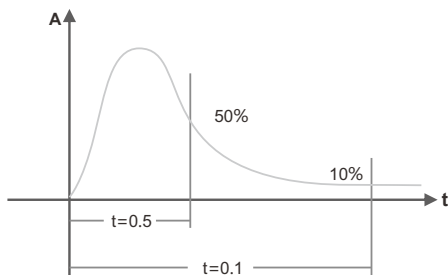

In M/Multi mode which without high-speed sync, flash duration is displayed on the LCD panel.

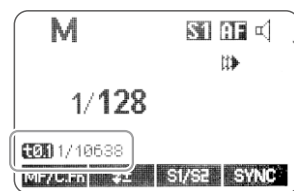

## Flash Mode — RPT: Stroboscopic Flash

With stroboscopic flash, a rapid series of flashes is fired. It can be used to capture a multiple images of a moving subject in a single photograph.

You can set the firing frequency (number of flashes per sec. expressed as Hz), the number of flashes, and the flash output.

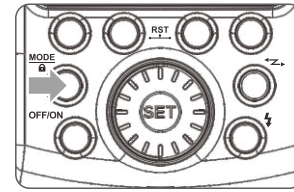

**1** Press <MODE> button so that <RPT> is displayed.

**2** Turn the Select Dial to choose a desired flash output.

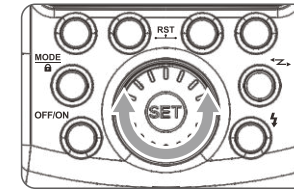

**3** Set the flash frequency and flash times.

- Press Function Button 3-<MULTI> button to select the flash times. Turn the Select Dial to set the number.
- Press Function Button 4-<Hz> button to select the flash times. Turn the Select Dial to set the number.
- After you finish the setting, press <SET> button and all the settings will be displayed.

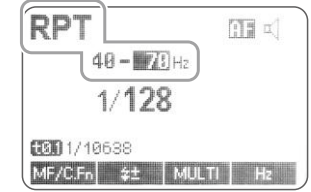

### Calculating the Shutter Speed

During stroboscopic flash, the shutter remains open until the firing stops. Use the formula below to calculate the shutter speed and set it with the camera.

### Number of Flashes / Flash Frequency = Shutter Speed

For example, if the number of flashes is 10 and the firing frequency is 5 Hz, the shutter speed should be at least 2 seconds.

- ⚠ To avoid overheating and deteriorating the flash head, do not use stroboscopic flash more than 10 times in succession. After 10 times, allow the camera flash to rest for at least 15 minutes. If you try to use the stroboscopic flash more than 10 times in succession, the firing might stop automatically to protect the flash head. If this happens, allow at least 15 minutes' rest for the camera flash.

- Stroboscopic flash is most effective with a highly reflective subject against a dark background.
- Using a tripod and a remote control is recommended.
- A flash output of 1/1 and 1/2 cannot be set for stroboscopic flash.
- Stroboscopic flash can be used with "buLb".
- If the number of flashes is displayed as "--", the firing will continue until the shutter closes or the battery is exhausted. The number of flashes will be limited as shown by the following table.

### Maximum Stroboscopic Flashes:

Flash Output \ Hz	1	2	3	4	5	6-7	8-9	10	20-50	60-100
1/4	7	6	5	4	4	3	3	2	2	2
1/8	14	14	12	10	8	6	5	4	4	4
1/16	30	30	30	20	20	20	10	8	8	8
1/32	60	60	60	50	50	40	30	20	16	12
1/64	90	90	90	80	80	70	60	50	30	20
1/128	90	90	90	90	90	90	80	70	40	40

# Wireless Flash: Optic Transmission

This product is compatible with Nikon Creative Lighting System (CLS). It can function as either an optic wireless master or slave flash. As a master unit, it can control Nikon speedlights e.g. SB-900 and SB-910 via wireless. As a slave unit, it can be controlled by wireless signals of Nikon speedlights e.g. SB-900 and pop-up flash commanders of Nikon cameras e.g. D7100/D7000/D800.

- You can set up three slave groups for i-TTL autoflash shooting. With i-TTL autoflash, you can easily create various lighting effects.
- Any flash settings for the slave units on the master flash in i-TTL/Manual/RPT mode will be automatically sent to the slave units. So the only thing you need to do is to set the master unit for each slave group without any operation for the slave units at all during the shooting.
- This flash can work in i-TTL/M/RPT/OFF flash modes when set as a master unit.

## Positioning and Operation Range

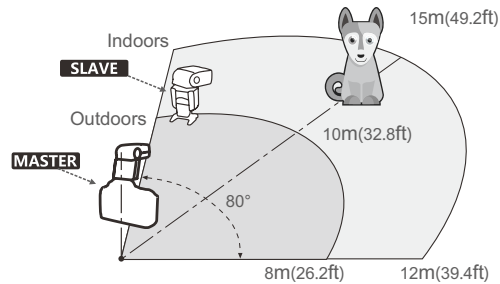

- Even with multiple slave units, the master unit can control all of them via wireless.
- In this user manual, "master unit" refers to the camera flash on a camera and "slave unit" will be controlled by the master unit.

## 1. Wireless Settings

You can switch between normal flash and wireless flash. For normal flash shooting, be sure to set the wireless setting to OFF.

### Master Unit Setting

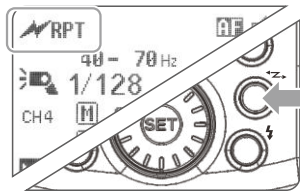

Press < > button so that < > or < > are displayed on the LCD panel. The backlight of LCD panel turns green now.

### Slave Unit Setting

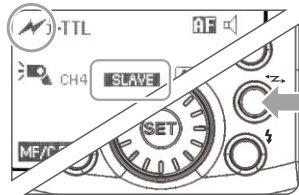

Press < > button again so that < > or < > are displayed on the LCD panel. The backlight of LCD panel turns orange now.

# Wireless Flash: Optic Transmission

## 2. Setting Master Unit's Flash Mode

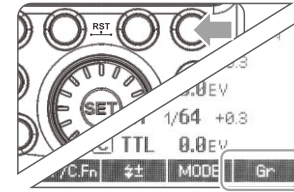

1 Press Function Button 4 < > to choose the group from M/A/B/C. Then, press Function Button 3 < > so that the master unit can work in OFF/i-TTL/M flash mode. Choose one of them as the flash mode of master unit.

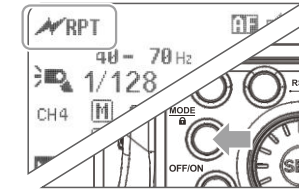

2 Press the "MODE/Lock" button can change to RPT mode.

## 3. Setting the Communication Channel

If there are other wireless flash systems nearby, you can change the channel IDs to prevent signal interference. The channel IDs of the master unit and the slave unit(s) must be set to the same.

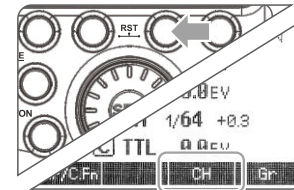

1 Press Function Button 3 < > and turn the Select Dial to choose a channel ID from 1 to 4.

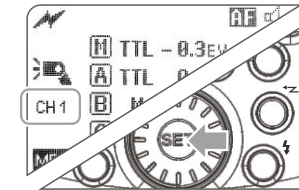

2 Press the <SET> button to confirm.

## 4. Wireless ID Settings

Change the wireless channels and wireless ID to avoid interference for it can only be triggered after the wireless IDs and channels of the master unit and the slave unit are set to the same. Press the <MENU> button to enter C.Fn ID. Press the <SET> button to choose OFF channel expansion shutdown, and choose any figure from 01 to 99.



# Wireless Flash: Optic Transmission

## 5. i-TTL: Fully Automatic Wireless Flash Shooting

### Using Automatic Wireless Flash with a Single Slave Unit



#### 1 Master Unit Setting

- Attach a AD360II-N camera flash on the camera and set it as the master Unit. (Page 40)
- M/A/B/C can be set as TTL mode independently.



#### 2 Slave Unit Setting

- Set the other AD360II-N as the wireless slave unit. (Page 40)
- The slave unit can be set as A/B/C.

#### 3 Check the communication channel.

- If the master unit and slave unit(s) are set to a different channel, set them to the same channel. (Page 41)

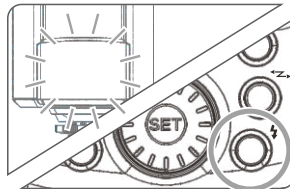

#### 4 Position the camera and flashes.

- Position the camera and flashes as the picture shows. (Page 39)

#### 5 Check that the flash is ready.

- Check that the master flash ready indicator is lightened.
- When the slave flash ready indicator is ready, the AF-assist beam lighting area will blink at 1 second intervals.

#### 6 Check the flash operation.

- Press the master unit's Test Button < ⚡ >.
- Then, the slave unit will fire. If not, adjust the slave unit's angle toward the master unit and distance from the master unit.

**!** The slave unit might be out of order or fire an unwanted flash due to the nearby fluorescent lamp or computer screen.

- If the slave unit's auto power off function is workable, press the master unit's test button to power it on. Please note that test firing is unavailable during the camera's regular metering time.
- By making some settings, the auto AF-assist transmitter will not blink after the slave unit's flash ready indicator is lightened. (C.Fn-AF/ Page 47)

### Using Fully Automatic Wireless Flash

The FEC and other settings that set on the master unit will also be appeared on the slave unit automatically. The slave unit does not need any operation. Use the following settings to make wireless flashes according to the same methods with normal flash shooting.

- Flash Exposure Compensation ( **±** / Page 35)
- High-Speed Sync ( **SYNC** / Page 36)

### About Master Unit

Use two or more master units. By preparing several cameras that with master units flash attached, cameras can be changed in shooting while keeping the same lighting source (slave unit).

# Wireless Flash: Optic Transmission

## 6. M: Wireless Flash Shooting with Manual Flash

This describes wireless (multiple shooting) using manual flash. You can shoot with a different flash output setting for each slave unit (firing group). Set all parameters on the master unit.

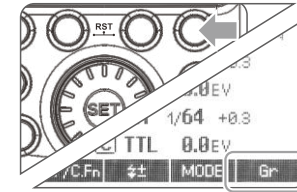

#### 1 Setting the flash mode to <M>.

- Press Function **Button 4** < **Gr** > to choose groups. Then, press Function **Button 3** < **MODE** > to set the flash to M mode.

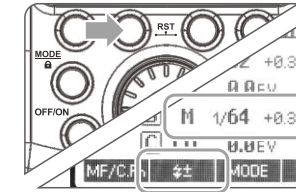

#### 2 Setting flash output.

- Press Function **Button 2** < **±** >. Turn the Select Dial to set the flash output of the groups. Press the < **SET** > button to confirm.

#### 3 Taking the picture.

Each group fires at the set flash ratio.

## 7. RPT: Wireless Flash Shooting with Manual Flash

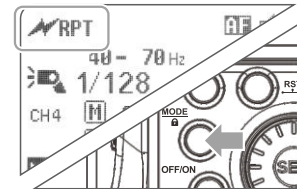

#### Setting <RPT> stroboscopic flash.

- Press < **MODE** > button so that < **RPT** > is displayed.
- Setting the stroboscopic flash. (Page 38)

**!** The firing frequency of stroboscopic flash during the optic transmission wireless shooting can be set from 1Hz to 100Hz.

# Wireless Flash Shooting: Radio (2.4G) Transmission

Using a flash (master/slave) with a radio transmission wireless shooting function make it easy to shoot with advanced wireless multiple flash lighting, in the same way as i-TTL autoflash shooting.

The basic relative position and operation range are as shown in the picture. You can then perform wireless i-TTL autoflash shooting just by setting the master unit to <TTL>.

AD360II-N adopts Godox 2.4G wireless X system, which can be used in combination with other products in our factory.

As a slave unit, AD360II-N is compatible with Canon E-TTL II and Nikon i-TTL systems. It will automatically change its system according to the master unit instead of setting by manual. Once received the master unit's signal, "Canon" or "Nikon" is displayed the LCD panel.

Nikon cameras (use X1T-N, TT685N, etc) and Canon cameras (use X1T-C, TT685C, etc) can use one or more AD360II-N flashes simultaneously.



\* As master unit, AD360II-N can control the following slave units: AD360II-C, AD360II-N, TT685N, X1R-N, TT600, etc.

\* As slave unit, AD360II-N can be controlled by the following master units: AD360II-C, AD360II-N, TT685C, TT685N, X1T-C, X1T-N, TT600, etc.

To use the flash with 2.4G wireless shooting functions (master/slave), use the same setting method as i-TTL autoflash. The positioning and operation range can be found in the following pictures. Set the master unit as <i-TTL> mode to wirelessly fire flashes.

## Positioning and Operation Range (Example of wireless flash shooting)

### • Autoflash Shooting with One Slave Unit

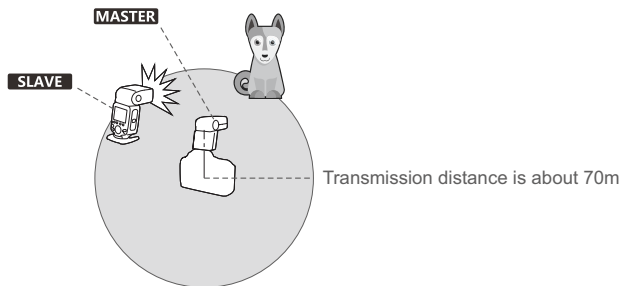

- Use the supplied mini stand to position the slave unit.
- Before shooting, perform a test flash and test shooting.
- The transmission distance might be shorter depending on the conditions such as positioning of slave units, the surrounding environment and whether conditions.

# Wireless Flash Shooting: Radio (2.4G) Transmission

## Wireless Multiple Flash Shooting

You can divide the slave units into two or three groups and perform i-TTL autoflash while changing the flash ratio (factor). In addition, you can set and shoot with a different flash mode for each firing group, for up to 5 groups.

### • Auto Shooting with Two Slave Groups



### • Auto Shooting with Three Slave Groups

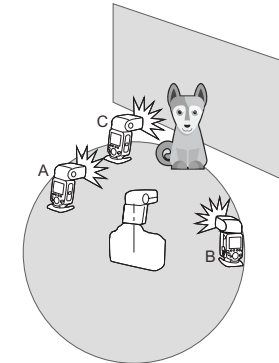

Wireless shooting using radio transmission has advantages over wireless shooting using optic transmission, such as being less affected by obstacles, and not having to point the slave unit's wireless sensor toward the master unit. The main functional differences are as follows:

Function	Radio Transmission	Optic Transmission
Distance	70m	Master (transmitter): approx. 3m; Slave (receiver): approx. 15m
Channel	1~32	1~4
To be disturbed	Hard	Easy

## ⚠ The Reason & Solution of Not Triggering in Godox 2.4G Wireless

- 1. Disturbed by the 2.4G signal in outer environment (e.g. wireless base station, 2.4G wifi router, Bluetooth, etc.)**  
→ To adjust the channel CH setting on the flash trigger (add 10+ channels) and use the channel which is not disturbed. Or turn off the other 2.4G equipment in working.
- 2. Please make sure that whether the flash has finished its recycle or caught up with the continuous shooting speed or not (the flash ready indicator is lighten) and the flash is not under the state of over-heat protection or other abnormal situation.**  
→ Please downgrade the flash power output. If the flash is in TTL mode, please try to change it to M mode (a preflash is needed in TTL mode).
- 3. Whether the distance between the flash trigger and the flash is too close or not**  
→ Please turn on the "close distance wireless mode" on the flash trigger (< 0.5m):  
X1 series: press the test button and hold on, then turning it on until the flash ready indicator blinks for 2 times.  
XPro series: Set the C.Fn-DIST to 0-30m.
- 4. Whether the flash trigger and the receiver end equipment are in the low battery states or not**  
→ Please replace the battery (the flash trigger is recommended to use 1.5V disposable alkaline battery).

## Other Applications

### Wireless Control Function

The flash unit is built in with a Wireless Control Port so that you can wirelessly adjust the power level of the flash and the flash triggering. To control the flash wirelessly, you need a FT-16 remote control set (on-camera and on-flash). Insert its receive end into the Wireless Control Port on the flash and insert the transmit end into the camera hot shoe. Settings made on the hotshoe-mounted transmit and receive ends will be wirelessly communicated to the flash. Then you can press the camera shutter release button to trigger the flash. You can also hold the transmit end at hand to control your off-camera flash.

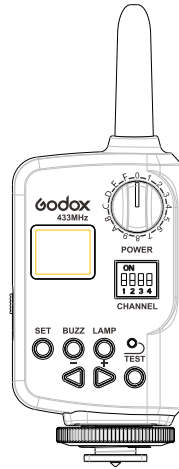
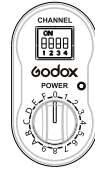

**i** For full instructions on the use of FT series remote control, see its user manual.

### Modeling Flash

If the camera has a depth-of-field preview button, pressing it will fire the flash continuously for 1 second. This is called modeling flash.

It enables you to see the shadow effects on the subject and the lighting balance. You can fire the modeling flash during wireless or normal flash shooting.

**i** To avoid overheating and deteriorating the flash head, do not fire the modeling flash for more than 10 consecutive times. If you fire the modeling flash 10 consecutive times, allow at least 10 minutes' break for the camera flash.

### Auto Focus Assist Beam

In poorly-lit or low-contrast shooting environments, the built-in auto focus assist beam will automatically light on to make it easier for autofocus. The beam will light up only when autofocus is difficult and get out as soon as the autofocus becomes correct.

If you want to turn off the auto focus assist beam, set the "AF" to "OFF" on the C.Fn settings.

**i** If you find the auto focus assist beam does not light up, this is because the camera has got a correct autofocus.

Position	Effective Range
Center	0.6~10m / 2.0~32.8 feet
Periphery	0.6~5m / 2.0~16.4 feet

### Assist Beam Setting

The flash has two ways to light on the assist beam: auto focus (AF) and manual focus (MF). Press Function Button 1 (MF/C.Fn) to choose.

**Auto focus (AF):** The assist beam is lighted on by camera.

**Manual focus (MF):** The assist beam is lighted on manually.

**Turn off the assist beam:** Set "AF" to OFF on the C.Fn menu, and the assist beam will be turned off.

## Other Applications

### Bounce Flash

By pointing the flash head toward a wall or ceiling, the flash will bounce off the surface before illuminating the subject. This can soften shadows behind the subject for a more natural-looking shot. This is called bounce flash.

To set the bounce direction, hold the flash head and turn it to a satisfying angle.

- i** If the wall or the ceiling is too far away, the bounced flash might be too weak and result in underexposure.
- The wall or the ceiling should be a plain, white color for high reluctance. If the bounce surface is not white, a color cast may appear in the picture.

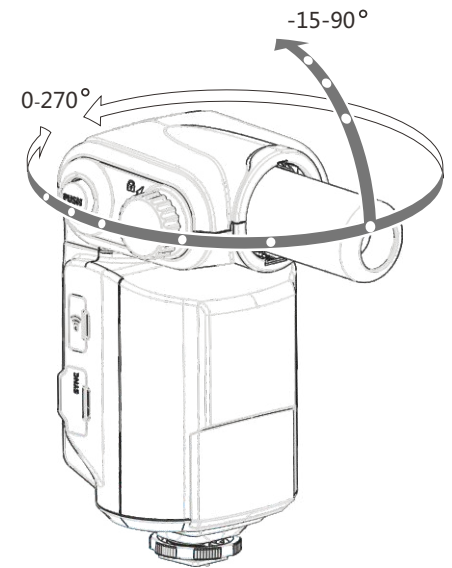

### Sync Triggering

The Sync Cord Jack is a  $\Phi 3.5\text{mm}$  plug. Insert a trigger plug here and the flash will be fired synchronously with the camera shutter.

### PC Sync Socket Triggering

Use remote cable to connect the camera and the AD360II-N through its PC sync socket, and the flash will be fired synchronously with the camera shutter.

## C.Fn: Setting Custom Functions

The following table lists the available and unavailable custom functions of this flash.

Custom Function Signs	Functions	Setting Signs	Settings & Descriptions
APO	Auto power off	ON	ON
		OFF	OFF
		- → 0 → +	
AF	AF-assist beam	ON	ON
		OFF	OFF
BEEP	Beeper	ON	ON
		OFF	OFF
LIGHT	Backlighting time	12sec	Off in 12 sec.
		OFF	Always off
		ON	Always lighting
LCD	LCD contrast ratio	0-9	10 levels
ID	Wireless ID	OFF	Off
		01-99	Choose any figure from 01-99
Sv LED	Wireless LED Lamp	OFF	Off
		ON	on

- Press < MF/C.Fn > Button for 2 seconds or longer until C.Fn menu is displayed. The "Ver x.x" in the top-right corner refers to the software version.
- Select the Custom Function No.
  - Turn the Select Dial to select the Custom Function Signs.
- Change the Setting.
  - Press < **SET** > button and the Setting No. blinks.
  - Turn the Select Dial to set the desired number. Pressing < **SET** > button will confirm the settings.
  - After you set the Custom Function and press < **MODE** > button, the camera will be ready to shoot.
- In the C.Fn states, long press the "Clear" button for 2 seconds until "OK" is displayed on the panel, which means the values in C.Fn can be reset.

## Protection Function

### 1. Over-Temperature Protection

- To avoid overheating and deteriorating the flash head, do not fire more than 75 continuous flashes in fast succession at 1/1 full power. After 30 continuous flashes, allow a rest time of at least 75 minutes.
- If you fire more than 75 continuous flashes and then fire more flashes in short intervals, the inner over-temperature protection function may be activated and make the recycling time over 10 seconds. If this occurs, allow a rest time of about 10 minutes, and the flash unit will then return to normal.
- When the over-temperature protection is started, ⚡ is shown on the LCD display.

**Number of flashes that will activate over-temperature protection:**

Power Output Level	Number of Flashes
1/1	75
1/2(+0.3,+0.7)	100
1/4(+0.3,+0.7)	150
1/8(+0.3,+0.7)	200
1/16(+0.3,+0.7)	300
1/32(+0.3,+0.7)	500
1/64(+0.3,+0.7)	1000
1/128(+0.3,+0.7)	

**Number of flashes that will activate over-temperature protection in high-speed sync triggering mode:**

Power Output	Times
1/1	30
1/2(+0.3,+0.7);	40
1/4(+0.3,+0.7)	50
1/8(+0.3,+0.7);	60
1/16(+0.3,+0.7)	75
1/32(+0.3,+0.7);	
1/64(+0.3,+0.7);	100
1/128(+0.3,+0.7);	

### 2. Other Protections

- The system provides real-time protection to secure the device and your safety. The following lists prompts for your reference:

LCD Panel	Meaning
E1	A failure occurs on the recycling system so that the flash cannot fire. Please restart the flash unit. If the problem still exists, please send this product to a maintenance center.
E2	The system gets excessive heat. Please allow a rest time of 10 minutes.
E3	The voltage on two outlets of the flash tube is too high. Please send this product to a maintenance center.
E9	There are some errors occurred during the upgrading process. Please using the correct firmware upgrade method.

## Technical Data

Model	AD360II-N	
•Type		
Compatible Cameras	Nikon DSLR cameras (i-TTL autoflash)	
Slave Unit Compatible Cameras	Canon EOS cameras, E-TTL II autoflash (master unit use TTL wireless flash trigger X1C, etc.) Nikon cameras, i-TTL autoflash (master unit use TTL wireless flash trigger use X1N, etc.)	
Guide No. (m ISO 100)	80 (m ISO 100, with AD-S2 standard reflector)	
Vertical Rotation Angle	-15° to 90°	
Horizontal Rotation Angle	0 to 270°	
Flash Duration	1/220 to 1/10000 seconds	
•Exposure Control		
Exposure control system	i-TTL autoflash and manual flash	
Flash exposure compensation (FEC)	Manual. FEB: ±3 stops in 1/3 stop increments (Manual FEC and FEB can be combined.)	
Sync mode	High-speed sync (up to 1/8000 seconds), first-curtain sync, and second-curtain sync	
Multi flash	Provided (up to 90 times, 100Hz)	
•Wireless Flash (Optic transmission and 2.4G transmission)		
Wireless flash function	Master, Slave, Off	
Controllable slave groups	3 (A, B, and C)	
Transmission	Optic	Master (transmitter): approx. 3m; Slave (receiver): Indoors: 12 to 15 m/ 39.4 to 49.2 ft.; Outdoors: 8 to 10 m/ 26.2 to 32.8ft. Reception angle: ±40° horizontally, ±30° vertically
	2.4G	70m (AD360II-N as a transmitter) 100m (X1C/X1N as a transmitter)
range (approx.)	Optic	4 (1, 2, 3, and 4)
	2.4G	32 (1-32)
Channels		
Slave-ready indicator	Two red indicators blink	
Modeling flash	Fired with camera's depth-of-field preview button	
•Power Supply		
Power Supply	GODOX PB960 lithium power pack	
Full Power Flashes	450 (with PB960 power pack)	
Recycle Time	Approx. 0.05-4.5s (with PB960 power pack)	
Power Saving	Power off automatically after approx. 60 minutes of idle operation.	
•Sync Triggering Mode	Hotshoe, 3.5mm sync line, PC sync socket, Wireless control port	
•Color Temperature	5600±200k	
•Dimensions		
Dimension	75*95*220mm (flash tube & reflector not included)	
Net Weight	800g (flash tube & reflector not included)	
2.4G Wireless Frequency Range	2412.99MHz-2464.49MHz	
Max. Transmitting Power of 2.4G Wireless	5dbm	

## Troubleshooting

If there is a problem, refer to this Troubleshooting Guide.

### The Camera Flash does not fire.

- The camera flash is not attached securely to the camera.  
→ Attach the camera's mounting foot securely to the camera.
- The electrical contacts of the Camera Flash and camera are dirty.  
→ Clean the contacts.

### The flash exposure is underexposed or overexposed.

- You used high-speed sync.  
→ With high-speed sync, the effective flash range will be shorter. Make sure the subject is within the effective flash range displayed.
- You used Manual Flash mode.  
→ Set the flash mode to i-TTL or modify the flash output.

**This flash supports firmware upgrade through the USB port. Update information will be released on our official website.**



USB connection line is not included in this product. The USB port is a standard Micro USB socket. Common USB connection line is applicable.

## Compatible Camera Models

This flash unit can be used on the following **Nikon DSLR series camera models**:

D800	D700	D7100	D7000	D5200	D5100	D5000
D300	D300S	D3200	D3100	D3000	D200	D70S
D810	D610	D90				



- This table only lists the tested camera models, not all Nikon DSLR series cameras. For the compatibility of other camera models, a self-test is recommended.
- Rights to modify this table are retained.

## Maintenance

- Shut down the device immediately should abnormal operation be detected.
- Avoid sudden impacts and the product should be dedusted regularly.
- It is normal for the flash tube to be warm when in use. Avoid continuous flashes if unnecessary.
- Maintenance of the flash must be performed by our authorized maintenance department which can provide original accessories.
- This product, except consumables e.g. flash tube, is supported with a one-year warranty.
- Unauthorized service will void the warranty.
- If the product had failures or was wetted, do not use it until it is repaired by professionals.
- Changes made to the specifications or designs may not be reflected in this manual.

# FCC Warning

---

This device complies with part 15 of the FCC Rules. Operation is subject to the following two conditions: (1) This device may not cause harmful interference, and (2) this device must accept any interference received, including interference that may cause undesired operation.

Any Changes or modifications not expressly approved by the party responsible for compliance could void the user's authority to operate the equipment.

**Note:** This equipment has been tested and found to comply with the limits for a Class B digital device, pursuant to part 15 of the FCC Rules. These limits are designed to provide reasonable protection against harmful interference in a residential installation. This equipment generates uses and can radiate radio frequency energy and, if not installed and used in accordance with the instructions, may cause harmful interference to radio communications. However, there is no guarantee that interference will not occur in a particular installation. If this equipment does cause harmful interference to radio or television reception, which can be determined by turning the equipment off and on, the user is encouraged to try to correct the interference by one or more of the following measures:

- ▶ -Reorient or relocate the receiving antenna.
- ▶ -Increase the separation between the equipment and receiver.
- ▶ -Connect the equipment into an outlet on a circuit different from that to which the receiver is connected.
- ▶ -Consult the dealer or an experienced radio/TV technician for help.

\*RF warning:

This equipment complies with FCC radiation exposure limits set forth for an uncontrolled environment. This equipment should be installed and operated with minimum distance 20cm between the radiator & your body.